

50132321

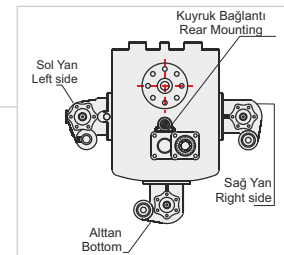
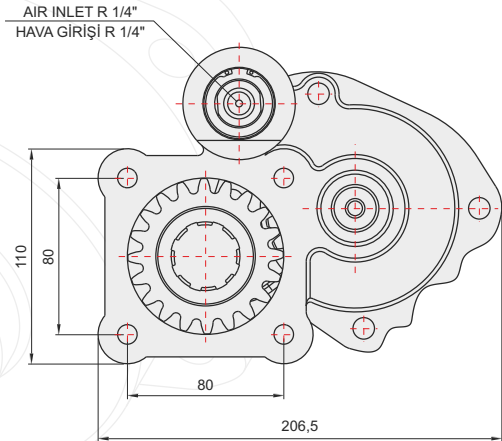
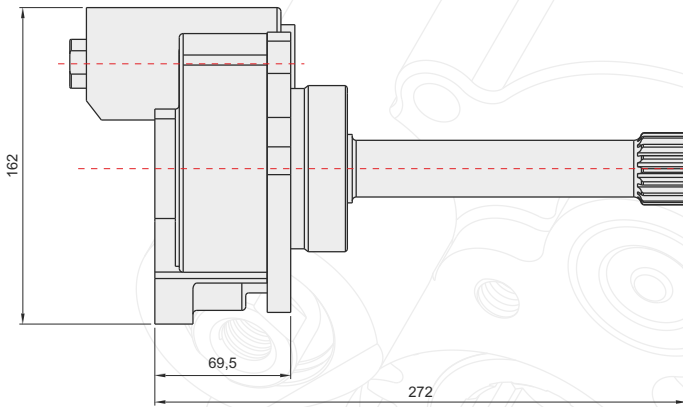
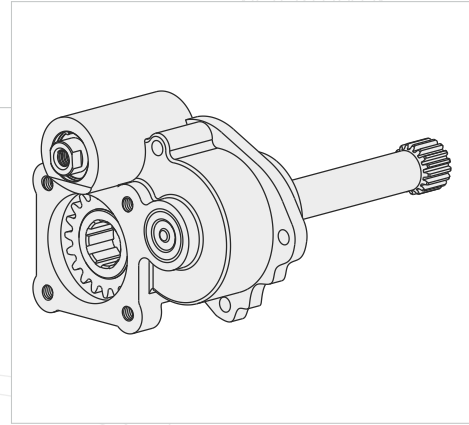

GENEL BİLGİLER/GENERAL DATA

P.T.O. KODU / P.T.O. CODE	50132321	
Tork / Torque	26,1 Kgm	256 Nm
Güç(1000 rpm) / Power	33,37 Hp	24,9 Kw
Devir / Speed	1000 rpm	1000 rpm
Oran / Ratio	1/1,2	1/1,2
Ağırlık / Weight	10 kg	22 lb
Bağlantı / Mounting	Kuyruk	Rear
Kumanda / Control	Havali	Pneumatic
Dönüş / P.T.O. Rotation	Sol - ISO	Left - ISO

Ana Şanzıman / Gearbox	Kullanılan Bazı Araçlar / Used Vehicles
G3 / 65-90	1217-1219-1413-1419-1422-1613-1619-1922K-2024-2067-MERCEDES-BENZ/ UNIMOG BENZ

Seçeğinizin pompanın dönüş yönü, P.T.O. dönüş yönü ile ters olmalıdır.
The rotation of the chosen pump has to be opposite with the rotation of P.T.O.

P.T.O. montaj edildikten sonra ana şanzıman yağını tamamlayın.
Fill the oil of the gear box after mounting the P.T.O.

POWER TAKE OFF

P.T.O.

P



KUYRUK/REAR

MERCEDES

G3/65-90 UNIMOG

ÜRÜN MONTAJ ve PARÇA LİSTESİ
PRODUCT ASSEMBLY and PART LIST

POWER TAKE OFF

P.T.O.

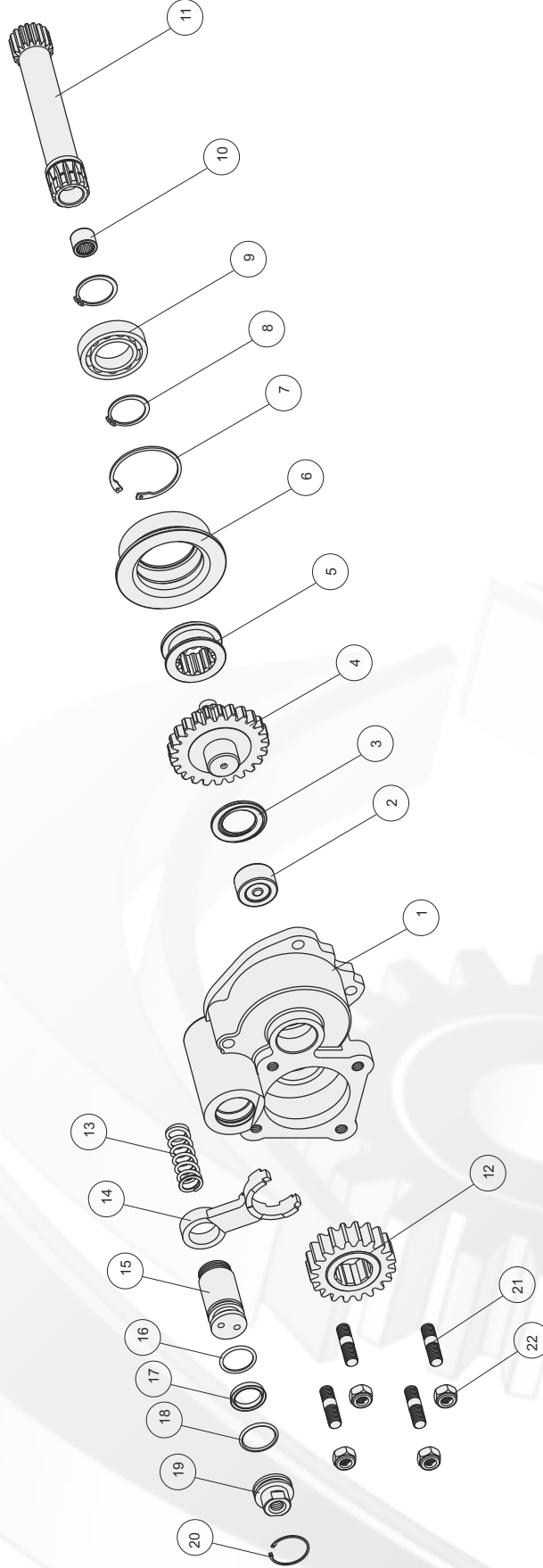

MERCEDES G3/65-90 UNIMOG

Adet	Parça No	Parça Adı	Kod
1	1	Gövde	50132321 -01
1	2	Bk 3020 Rulman	50132321 -02
1	3	Bronz Pul	50132321 -03
1	4	Grup Dişlisi	50132321 -04
1	5	Senkromeç	50132321 -05
1	6	Merkezleme Pulü	50132321 -06
1	7	472-62 Segman	50132321 -07
2	8	471-35 Segman	50132321 -08
1	9	6007 Rulman	50132321 -09
1	10	Hk 1616 Rulman	50132321 -10
1	11	Kardan Mili	50132321 -11

Adet	Parça No	Parça Adı	Kod
1	12	8x20 Dişli	50132321 -12
1	13	Yay	50132321 -13
1	14	Hilal	50132321 -14
1	15	Pnömatik Piston	50132321 -15
1	16	3x27 O-ring	50132321 -16
1	17	33x25x5.5 Nutring	50132321 -17
1	18	29,75x3,53 O-ring	50132321 -18
1	19	Pnömatik Kapak	50132321 -19
1	20	472-36 Segman	50132321 -20
4	21	M12x45 Saplama	50132321 -21
4	22	M12 Somun	50132321 -22
29	TOPLAM PARÇA SAYISI		