

50127321

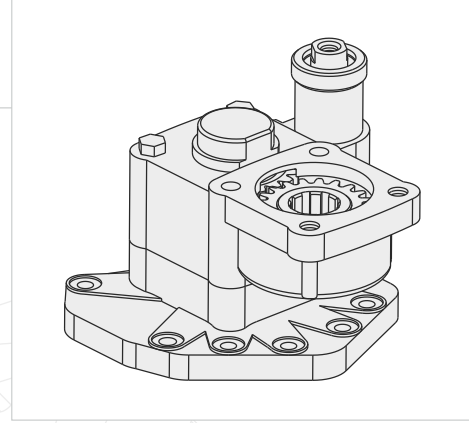

AIR INLET R 1/4"
HAVA GİRİŞİ R 1/4"

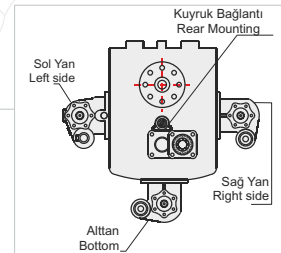
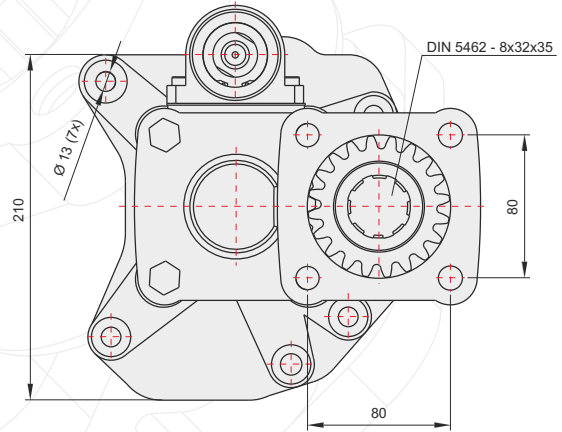
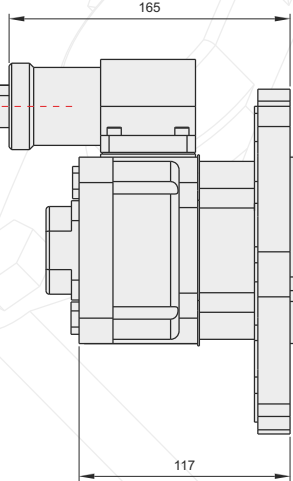

GENEL BİLGİLER/GENERAL DATA

P.T.O. KODU / P.T.O. CODE	50127321	
Tork / Torque	28 Kgm	275 Nm
Güç(1000 rpm) / Power	57,7 Hp	43 Kw
Devir / Speed	675 rpm	675 rpm
Oran / Ratio	1/1,12	1/1,12
Ağırlık / Weight	16,6 kg	36,6 lb
Bağlantı / Mounting	Kuyruk	Rear
Kumanda / Control	Havalı	Pneumatic
Dönüş / P.T.O. Rotation	Sol - ISO	Left - ISO

Ana Şanzıman / Gearbox	Kullanılan Bazı Araçlar / Used Vehicles
G 125-135-155-180-200-210-221-240-255-260	1729-1735-1827-1834-1838-1929-1935-2038-2429-2435-2527-2531-2534-2629-2631-2635-2638-3229-3234-3534-3535-1831-1835-1840-1844-1848-1850-1857-1934-1938-1953-2044-2050-2544-2550-2650-2643-2644-3031-3234-3331-3348-4148-3331-3535-3336-3340-3235-3340-2031-2040-2648-3548-3553-3557-3538
	ACTROS MERCEDES BENZ

Seçeğinizin pompanın dönüş yönü, P.T.O. dönüş yönü ile ters olmalıdır.
The rotation of the chosen pump has to be opposite with the rotation of P.T.O.

P.T.O. montaj edildikten sonra ana şanzıman yağını tamamlayın.
Fill the oil of the gear box after mounting the P.T.O.

MERCEDES G155-2

POWER TAKE OFF

P.T.O.

ÜRÜN MONTAJ ve PARÇA LİSTESİ
PRODUCT ASSEMBLY and PART LIST

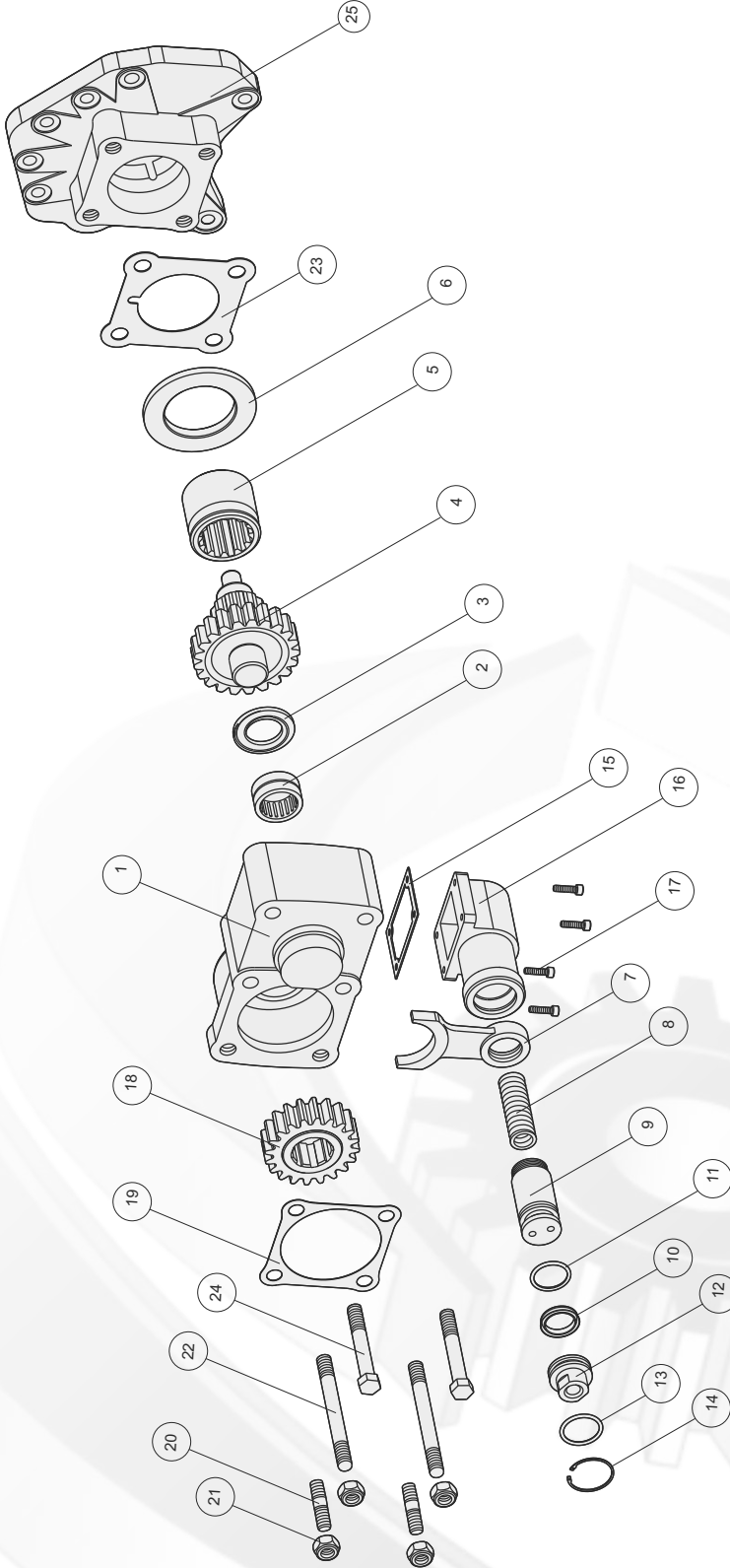

MERCEDES G155-2

Adet	Parça No	Parça Adı	Kod
1	1	Gövde	50127321-01
1	2	Nk 30/20A Rulman	50127321-02
1	3	31x52x4 Bronz Pul	50127321-03
1	4	Grup Dişlisi	50127321-04
1	5	Kavrama Dişlisi	50127321-05
1	6	G155-2 Ortalayıcı Pul	50127321-06
1	7	Hilal	50127321-07
1	8	Pnömatik Yay	50127321-08
1	9	Pnömatik Piston	50127321-09
1	10	3x27 O-ring	50127321-10
1	11	33x25x5.5 Nutring	50127321-11
1	12	Pnömatik Kapak	50127321-12
1	13	29,75x3,53 O-ring	50127321-13

Adet	Parça No	Parça Adı	Kod
1	14	472-36 Segman	50127321-14
1	15	Pnömatik kovan contası	50127321-15
1	16	Pnömatik kovan	50127321-16
4	17	M6x20 Cıvata	50127321-17
1	18	8x20 Dişli	50127321-18
1	19	Zf1 Conta	50127321-19
2	20	M12x45 Saplama	50127321-20
4	21	M12 Somun	50127321-21
2	22	M120x20 Saplama	50127321-22
1	23	Zf2 Conta	50127321-23
2	24	M12x90 Cıvata	50127321-24
1	25	G100 Plate	50127321-25
34	TOPLAM PARÇA SAYISI		