

50424511

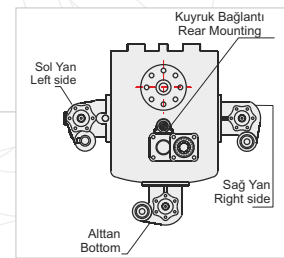
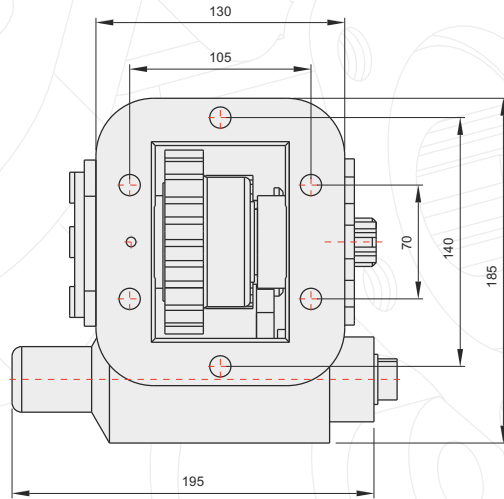
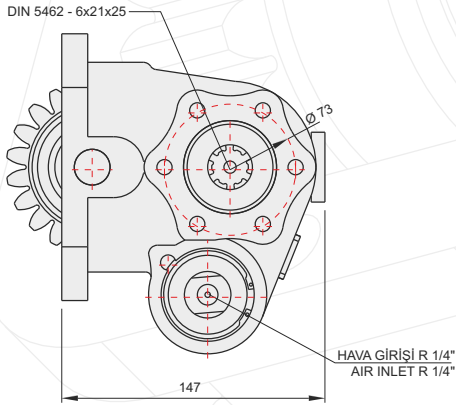
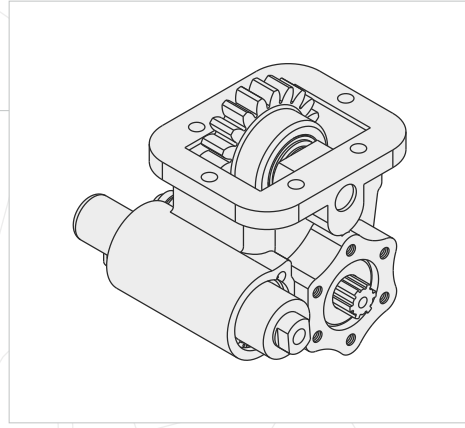

POWER TAKE OFF

P.T.O.

GENEL BİLGİLER/GENERAL DATA

P.T.O. KODU / P.T.O. CODE	50424511	
Tork / Torque	21 Kgm	206 Nm
Güç(1000 rpm) / Power	10,8 Hp	8,1 Kw
Devir / Speed	375 rpm	375 rpm
Oran / Ratio	4/5	4/5
Ağırlık / Weight	11 kg	24,3 lb
Bağlantı / Mounting	Sol	Left
Kumanda / Control	Havali	Pneumatic
Dönüş / P.T.O. Rotation	Sol - UNI	Left - UNI

Ana Şanzıman / Gearbox	Kullanılan Bazı Araçlar / Used Vehicles
EATON FS / FSV / FSO/H/V 6109-6209-8209-8309 A	214.26-220.26-280 FATİH / 2520L-2621 FORD CARGO 522-822-620 BMC 280 / FODEN 3000 26.234-26.264-26.284 MAN 6X2 EURO / SEDDON 211 / NISSAN CPC 16 / RENAULT MIDLUM 270 TATA LPTA 1621 TC 6x6 - LPS4021 TC

Seçtiğiniz pompanın dönüş yönü, P.T.O. dönüş yönü ile ters olmalıdır.
The rotation of the chosen pump has to be opposite with the rotation of P.T.O.

P.T.O. montaj edildikten sonra ana şanzıman yağını tamamlayın.
Fill the oil of the gear box after mounting the P.T.O.

ÜRÜN MONTAJ ve PARÇA LİSTESİ
PRODUCT ASSEMBLY and PART LIST

POWER TAKE OFF

P.T.O.

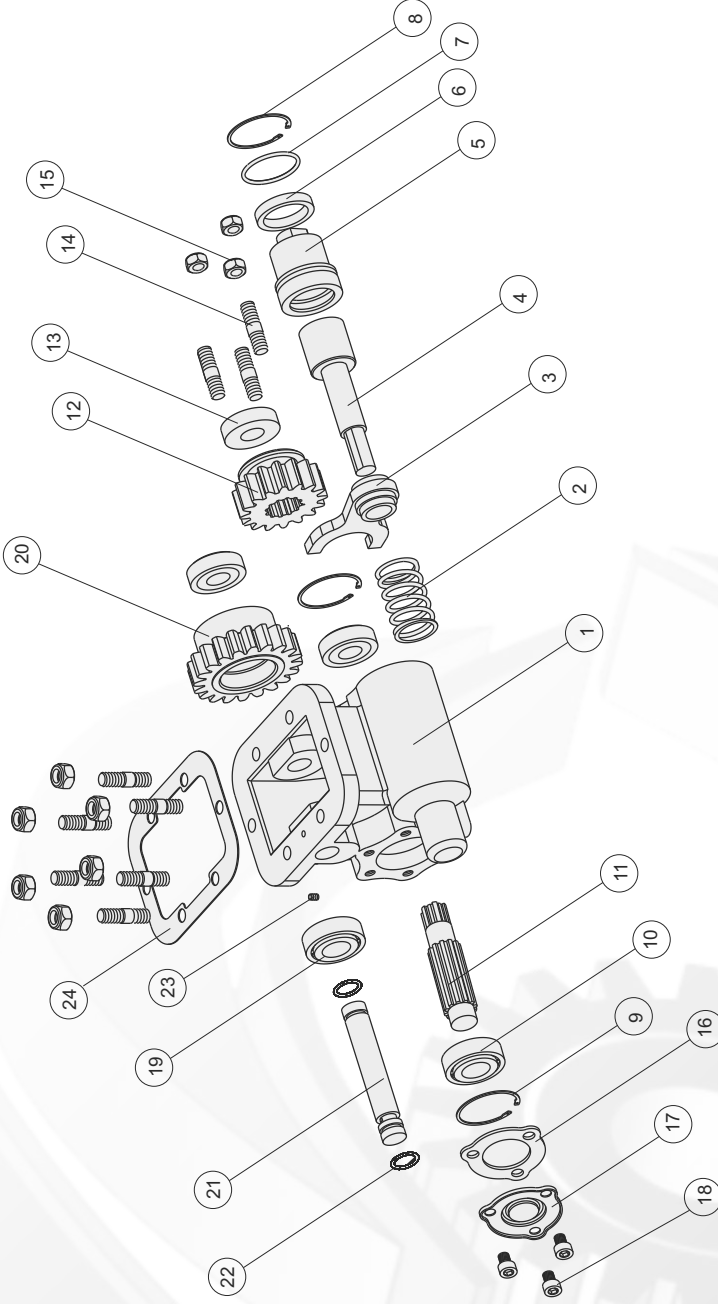

EATON 6109

Adet	Parça No	Parça Adı	Kod
1	1	Gövde	50424511-01
1	2	Yay	50424511-02
1	3	Hilal	50424511-03
1	4	Prömatik Mil	50424511-04
1	5	Prömatik Kovan	50424511-05
1	6	38x48,1x8 Nutring	50424511-06
1	7	3,53x42,86 O-ring	50424511-07
1	8	Tel Segman	50424511-08
2	9	472-52 Segman	50424511-09
2	10	6205 Rulman	50424511-10
1	11	6x12 Mil	50424511-11
1	12	Alt Dişli	50424511-12
1	13	Conta	50424511-13

Adet	Parça No	Parça Adı	Kod
1	14	Pto Yan Kapak	50424511-14
3	15	M10x16 Civata	50424511-15
1	16	25x52x10 Keçe	50424511-16
9	17	M10x45 Saplama	50424511-17
9	18	M10 Somun	50424511-18
2	19	30204 Rulman	50424511-19
1	20	Üst Dişli	50424511-20
1	21	Üst Mil	50424511-21
2	22	2,35x20 O-ring	50424511-22
1	23	M6x10 Setskur	50424511-23
1	24	Conta	50424511-24
46		TOPLAM PARÇA SAYISI	