

MERCEDES ATEGO 7 DELİK AKTARMALI UNI

## MERCEDES ATEGO 7 HOLES DOUBLE GEAR UNI

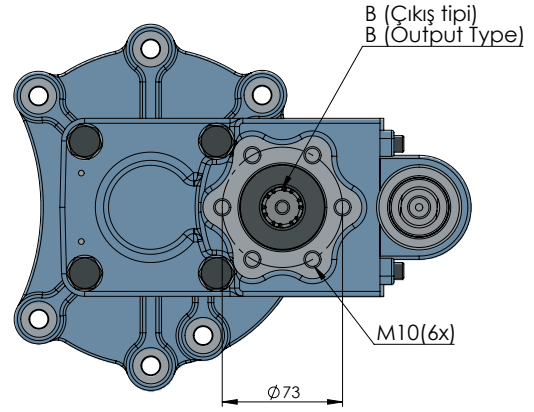
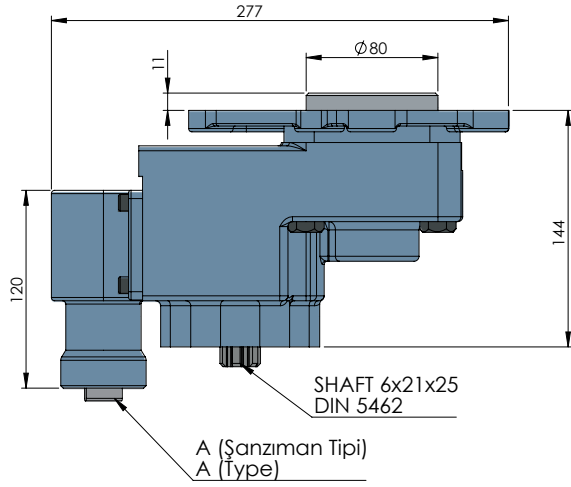
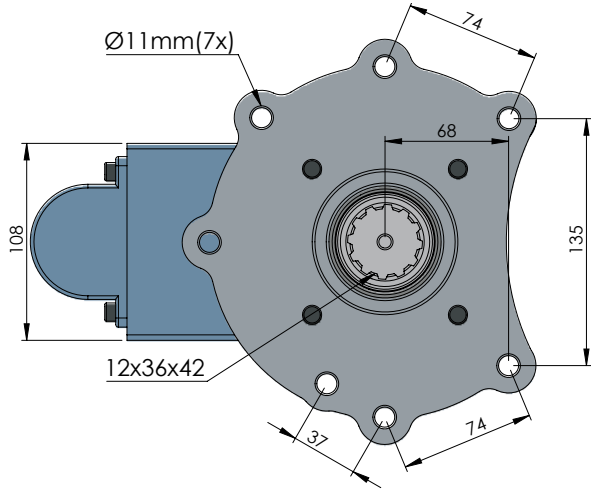

CODE KOD	TYPE TİP (A)	MOUNTING TYPE BAĞLANTI TİPİ (B)	MOUNTING SIDE BAĞLANTI	TORQUE TORK (Kgm / Nm)	POWER GÜÇ (Hp / Kw)	SPEED DEVİR (RPM)	RATIO ORAN
50122311P0	PNEUMATIC PNÖMATİK	UNI	REAR KUYRUK	22,4 Kgm 219,7 Nm	20 Hp 14,9 Kw	650	1:1,12
50122321P0		ISO ADAPTER ADAPTÖRLÜ ISO					
50122331P0		FLANGE FLANŞLI					
50122341P0		SHAFT ŞAFTLI					
GEARBOX / ANA ŞANZIMANLAR				USED VEHICLES / KULLANILAN BAZI ARAÇLAR			
G 60-6 (9,20) / G 85-6 (6,70) G 90-6 / G 71-6 / G 70-6				614-712-715-812-814-815-818-817-823-917-923-925-1017-1023-1328-1215-1217-1223-1225-1323-1325-1518-1528-2124-1317-1323-1328-1517-1523-1618-1623-1823 ATEGO / U 400 UNIMOG / 1118-1318-2124 ATEGO 2010 MODEL			

Seçtiğiniz pompanın dönüş yönü, P.T.O. dönüş yönü ile ters olmalıdır.  
The rotation of the chosen pump has to be opposite with the rotation of P.T.O.

P.T.O. montaj edildikten sonra ana şanzıman yağını tamamlayın.  
Fill the oil of the gear box after mounting the P.T.O.

management of power

MERCEDES

HIPOSAN

POWER TAKE-OFFS  
P.T.O.