

ZF-1 KUYRUK TEK DİŞLİ MÜŞÜRLÜ ISO

ZF-1 SINGLE GEAR WITH SWITCH ISO

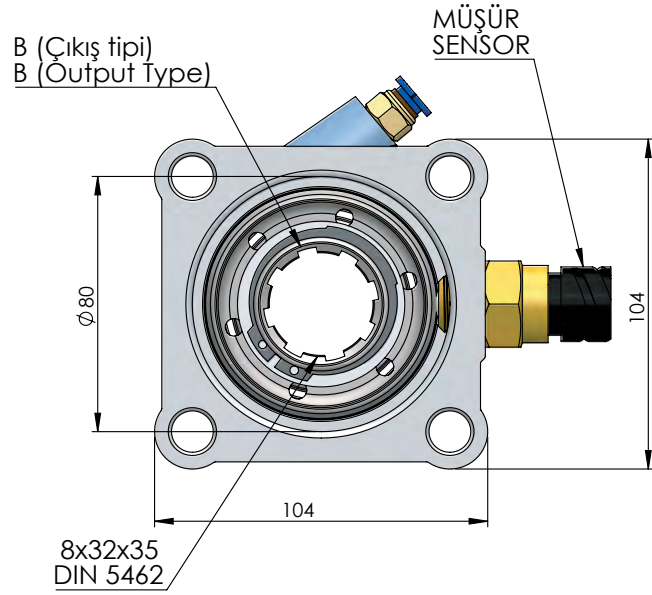
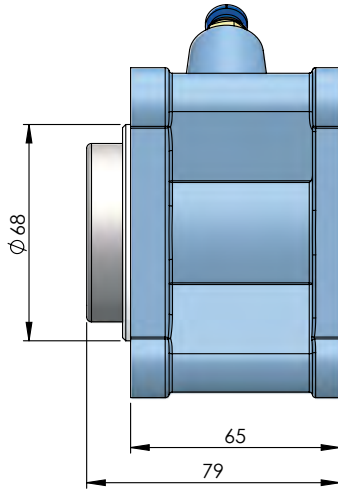
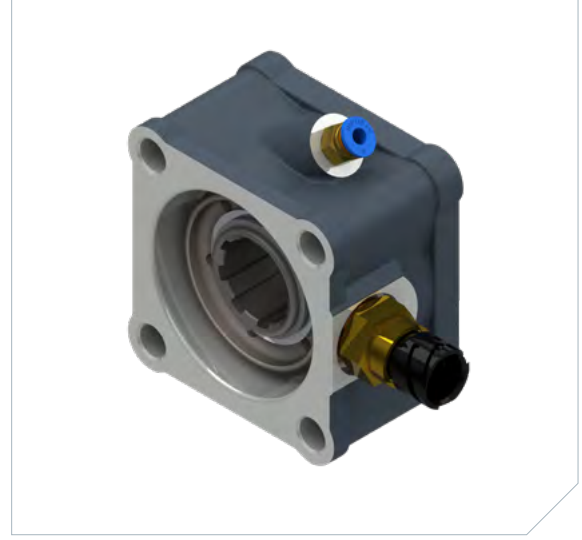
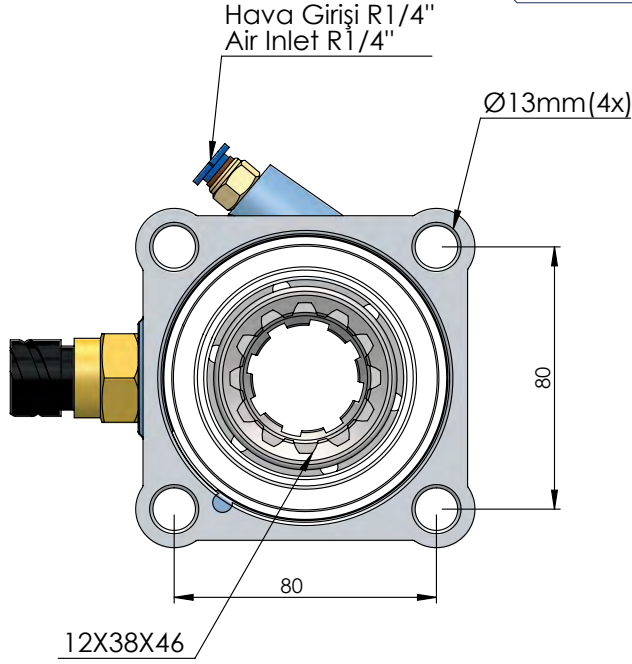

ZF

P.T.O. POWER TAKE-OFFS

CODE KOD	TYPE TİP (A)	MOUNTING TYPE BAĞLANTI TİPİ (B)	MOUNTING SIDE BAĞLANTI	TORQUE TORK (Kgm / Nm)	POWER GÜÇ (Hp / Kw)	SPEED DEVİR (RPM)	RATIO ORAN
50210312P1	PNEUMATIC Pnömatik	UNI ADAPTER ADAPTÖRLÜ UNI	REAR KUYRUK	23 Kgm 255 Nm	16 Hp 12 Kw	500	1:1
50210322P1		ISO					
50210332P1		FLANGE ADAPTÖRLÜ FLANŞLI					
50210342P1		SHAFT ADAPTÖRLÜ ŞAFTLI					
GEARBOX / ANA ŞANZİMANLAR				USED VEHICLES / KULLANILAN BAZI ARAÇLAR			
ZF44, ZF6S800, ZF6S1000, ZFS635, ZFS642, ZFS650, ZFS655, ZFS665, ZFS670, ZFS680, ZFS690, ZFS550, ZFS590, GV90, VOLVO2855/ZF S5/AK/65-120-111-110-92 GP ZF S5/AK/ 65-90-80-70-66-65-55-50-42-36-35 ZF AK 6 80 / AK 6 90 / S6 80 / S6 90				MAN/MERCEDES/BMC PROFESYONEL/FORD CARGO/CHRYSLER HINO/DODGE/FARGO/ HYUNDAI/ASTRAIVECO/DAF/DAEWOO/RENAULT/EBRO/GUY/AVIA/SAURER/SISU/STEYR			