

SCANIA GR871

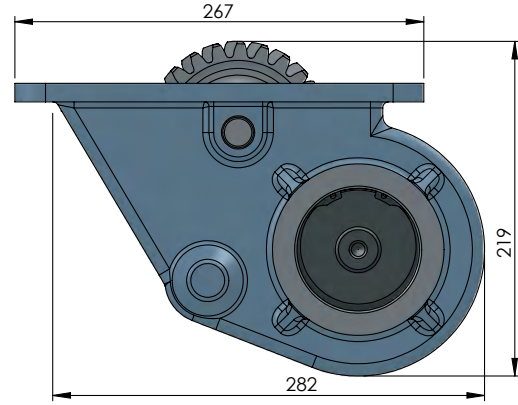
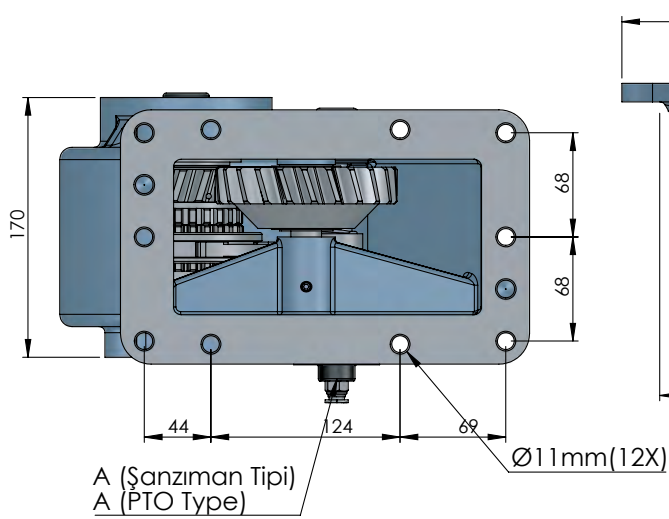
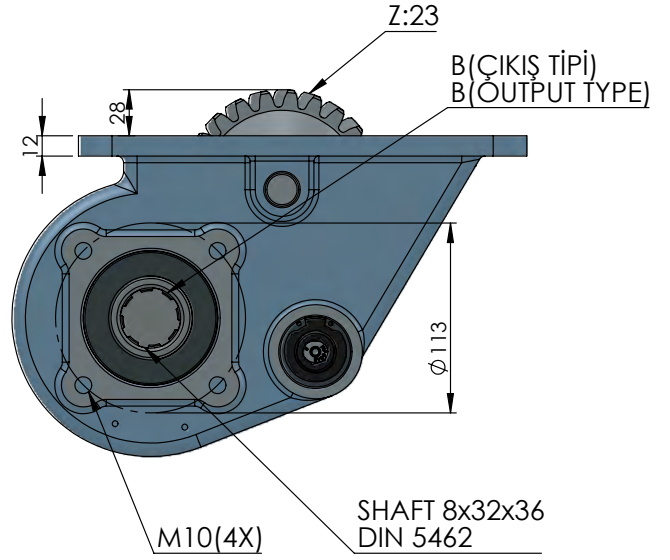

CODE KOD	TYPE TİP (A)	MOUNTING TYPE BAĞLANTI TİPİ (B)	MOUNTING SIDE BAĞLANTI	TORQUE TORK (Kgm / Nm)	POWER GÜÇ (Hp / Kw)	SPEED DEVİR (RPM)	RATIO ORAN
50316512P0	PNEUMATIC PNÖMATİK	UNI ADAPTER ADAPTÖRLÜ UNI	SIDE YAN	29 Kgm 284 Nm	37,5 Hp 27,6 Kw	1000 RPM	1:1
50316522P0		ISO					
50316532P0		FLANGE ADAPTÖRLÜ FLANŞLI					
50316542P0		SHAFT ADAPTÖRLÜ ŞAFTLI					
GEARBOX / ANA ŞANZIMANLAR				USED VEHICLES / KULLANILAN BAZI ARAÇLAR			
GR870-871 PTO SCANIA (1000 RPM, SAĞ)				P92-93-111-112C-113R-114H-142M-144L-93H-280-R113M			