

ZF 6S 400 YAN UNI

ZF 6S 400 SIDE UNI

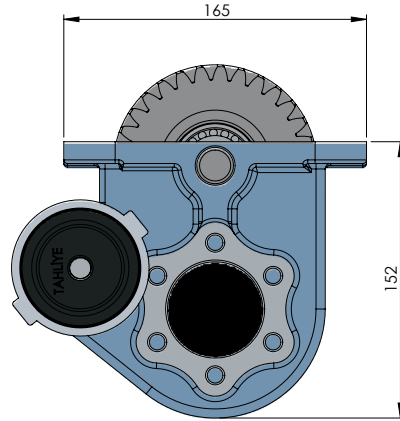
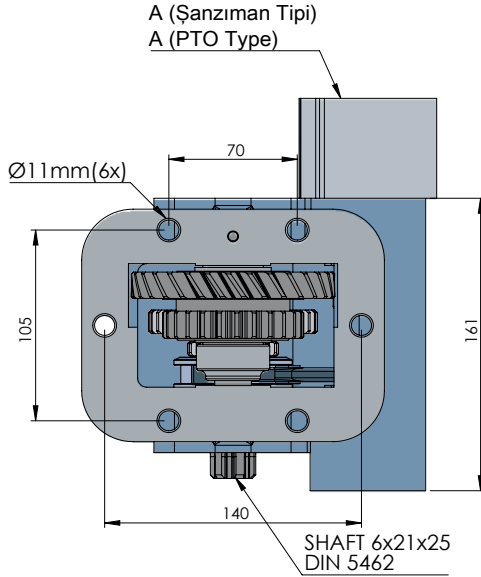
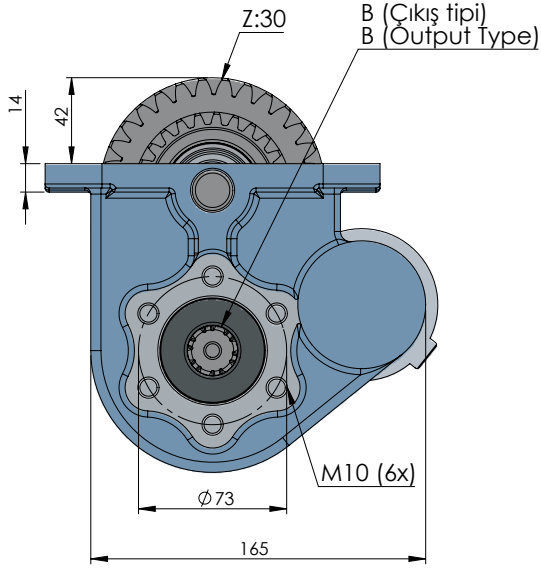

CODE KOD	TYPE TİP (A)	MOUNTING TYPE BAĞLANTI TİPİ (B)	MOUNTING SIDE BAĞLANTI	TORQUE TORK (Kg / Nm)	POWER GÜÇ (Hp / Kw)	SPEED DEVİR (RPM)	RATIO ORAN
50216522M0	MECHANİK MEKANİK	PTO OUTLET TYPE PTO ÇIKIŞ TİPİ (B)	SIDE YAN	21 Kg 206 Nm	36 Hp 22 Kw	700	1:0.8
50216532M0		UNI					
50216542M0		ISO ADAPTER ADAPTÖRLÜ ISO					
50216542M0		FLANGE FLANŞLI					
50216512V0	VACUUM VAKUMLU	UNI	SIDE YAN	21 Kg 206 Nm	36 Hp 22 Kw	700	1:0.8
50216522V0		ISO ADAPTER ADAPTÖRLÜ ISO					
50216532V0		FLANGE FLANŞLI					
50216542V0		SHAFT ŞAFTLI					
GEARBOX / ANA ŞANZIMANLAR				USED VEHICLES / KULLANILAN BAZI ARAÇLAR			
ZF 6S 380 / 6S 400 / IVECO SpA 2840.623M0 / IVECO SpA 2840.618D11				IVECO 45C15 - DAILY 4X4 - 50C18 - 35C15 - 50C15 - IVECO 65C15 - 70C15 - IVECO DAILY 4X4 55S18 / NISSAN ATLEON 56.15 /			

Seçeğinizin pompanın dönüş yönü, P.T.O. dönüş yönü ile ters olmalıdır.  
The rotation of the choosen pump has to be opposite with the rotation of P.T.O.

P.T.O. montaj edildikten sonra ana şanzıman yağını tamamlayın.  
Fill the oil of the gear box after mounting the P.T.O.

management of power

ZF

P.T.O. POWER TAKE-OFFS