

MERCEDES G4-2 DOUBLE GEAR UNI

MERCEDES G4-2 AKTARMA UNI

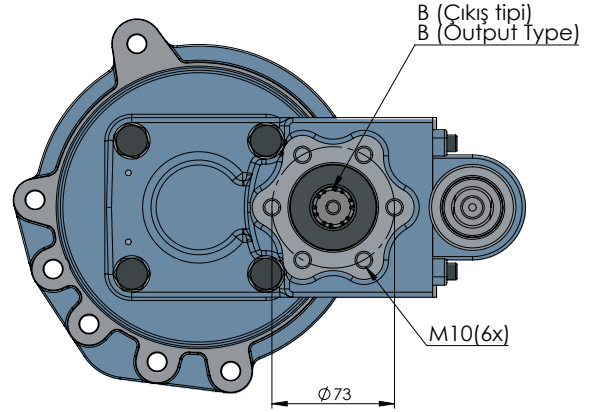
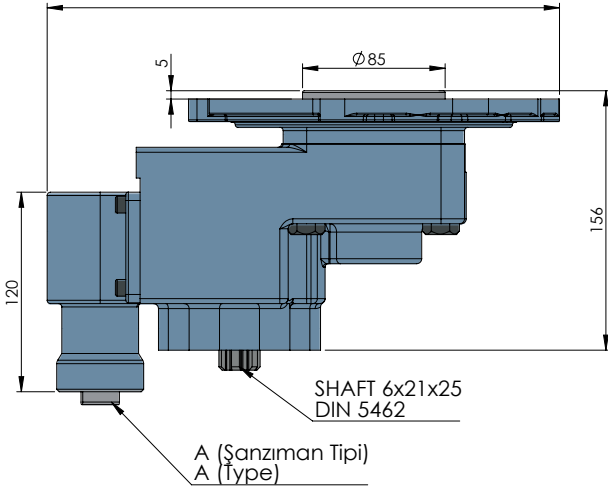
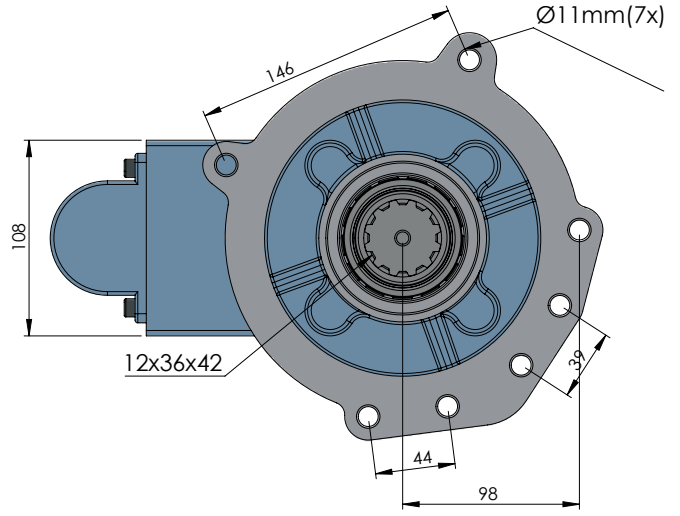

CODE KOD	TYPE TİP (A)	MOUNTING TYPE BAĞLANTI TİPİ (B)	MOUNTING SIDE BAĞLANTI	TORQUE TORK (Kgm / Nm)	POWER GÜÇ (Hp / Kw)	SPEED DEVİR (RPM)	RATIO ORAN
50129311P0	PNEUMATIC Pnömatik	UNI	REAR KUYRUK	22,4 Kgm 219,7 Nm	20 Hp 14,9 Kw	650	1:1,12
50129321P0		ISO ADAPTER ADAPTÖRLÜ ISO					
50129331P0		FLANGE FLANŞLI					
50129341P0		SHAFT ŞAFTLI					
GEARBOX / ANA ŞANZIMANLAR				USED VEHICLES / KULLANILAN BAZI ARAÇLAR			
G4 - GV / 4 65,90,95,110				1222-1224-1417-1419-1617-1619-1620-1722-1733-1817-1820-1821-1827-1831-1922-2232-2517 -2521-2527-3027-1424-1628-1820-1824-1929-1935-1948-2024-2222-2426-2524-2622-2629-2635 MERCEDES-BENZ			

MERCEDES

HIPOSAN®

POWER TAKE-OFFS
P.T.O.