

SCANIA GR900 UNI

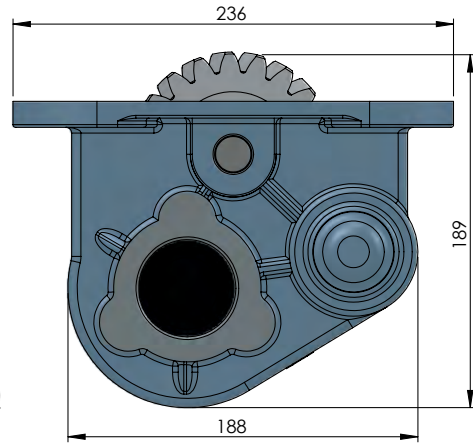
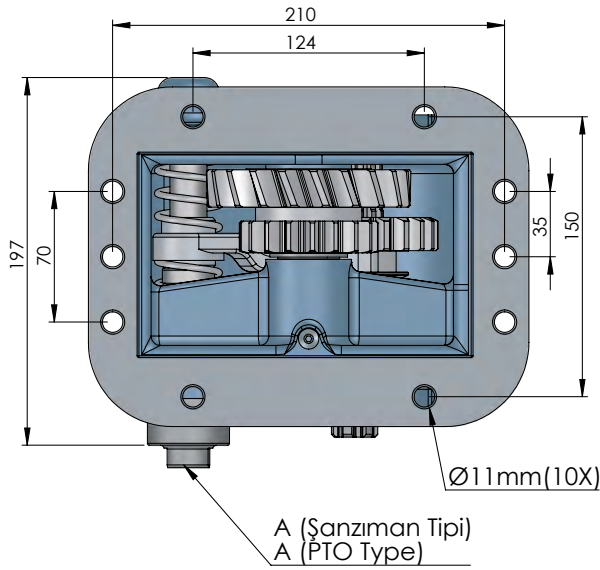
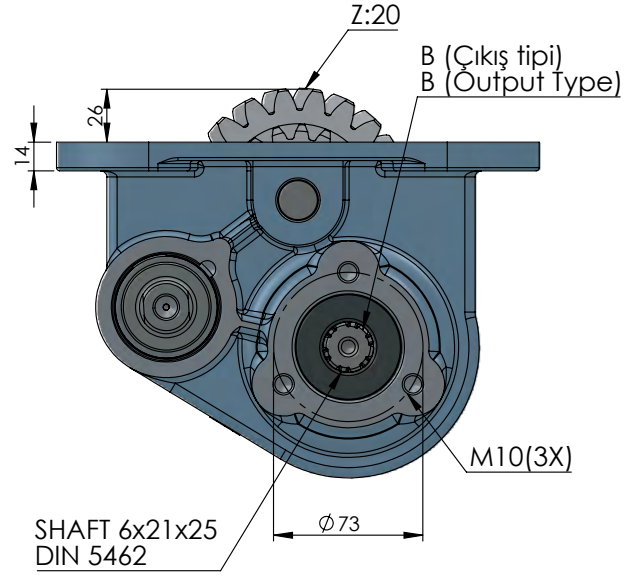

CODE KOD	TYPE TİP (A)	MOUNTING TYPE BAĞLANTI TİPİ (B)	MOUNTING SIDE BAĞLANTI	TORQUE TORK (Kgm / Nm)	POWER GÜÇ (Hp / Kw)	SPEED DEVİR (RPM)	RATIO ORAN
50310512P0	PNEUMATIC PNÖMATİK	UNI	SIDE YAN	25 Kgm 245 Nm	45.3 Hp 33.8 Kw	1065 RPM	01:00,8
50310522P0		ISO ADAPTER ADAPTÖRLÜ ISO					
50310532P0		FLANGE FLANŞLI					
50310542P0		SHAFT ŞAFTLI					
GEARBOX / ANA ŞANZIMANLAR				USED VEHICLES / KULLANILAN BAZI ARAÇLAR			
GR 900/ GRH 900 (1065 RPM, SAĞ)				94 C 310-124 C 360-R 124 GB 360-124 G 360-143 H 450 CV-143M 400 CV-260H-143H/P 113M- P114-GA 380-114P-124R-113P-114R-113H 360			