

ZF 6S 850 EĞİK HAVA YASTIKLI ISO

ZF 6S 850 BENT AXIS DOUBLE GEAR ISO

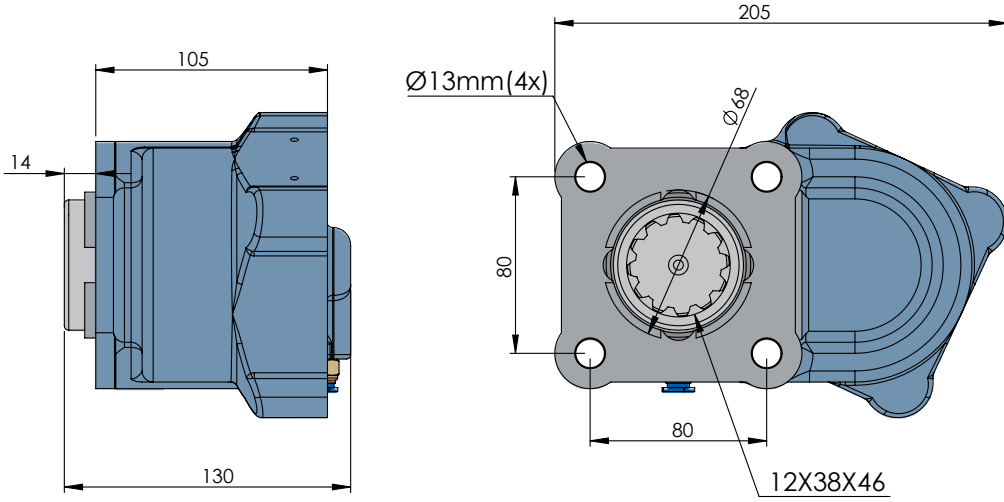
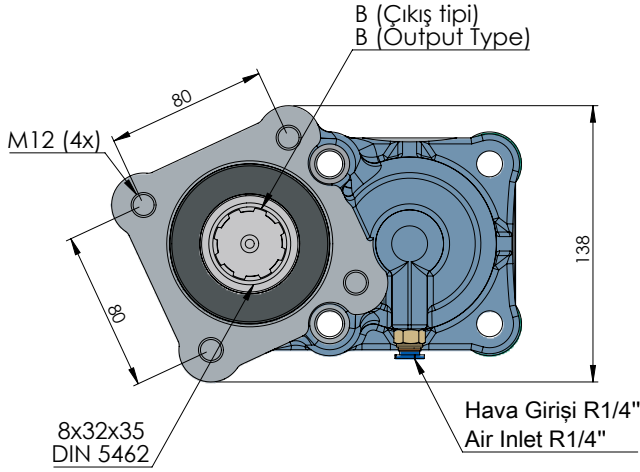

ZF

POWER TAKE-OFFS
 P.T.O.

CODE KOD	TYPE TİP (A)	MOUNTING TYPE BAĞLANTI TİPİ (B)	MOUNTING SIDE BAĞLANTI	TORQUE TORK (Kgm / Nm)	POWER GÜÇ (Hp / Kw)	SPEED DEVİR (RPM)	RATIO ORAN
50251311P0	PNEUMATIC PnöMATİK	UNI ADAPTER ADAPTÖRLÜ UNI	REAR KUYRUK	22,4 Kgm 219,7 Nm	20 Hp 14,9 Kw	650	1:1,21
50251321P0		ISO					
50251331P0		FLANGE ADAPTÖRLÜ FLANŞLI					
50251341P0		SHAFT ADAPTÖRLÜ ŞAFTLI					
GEARBOX / ANA ŞANZİMANLAR				USED VEHICLES / KULLANILAN BAZI ARAÇLAR			
ZF ECOLITE 6 S 850 - 6S-800 TO/6S700 TO/ZF 6 AS 700 / ZF 44/ZF S5-35-45/ S6-36-GV 66- GV S6 650- GV S 5 18 /S5-35-45 (650 RPM, SOL)				8.163-10.185-L 160C-LE 12.160-12.163-12.185-LE 18.220-18.225-18.230-18.240 MAN / 518-522 PRO / DAEWOO AVIA (CEK CUM.) / 180.18-180.25-280.25-280.26 FATİH BMC / LF55-CF65- CF75 DAF / ASHOK LEYLAND / 815 ATEGO / 28.280 MAN / TGL 8.180-12.180 100E18-120E18-150E18 EUROARGO EURO5 IVECO / KAMAZ 4308-43253			