

FULLER 11609 UNI

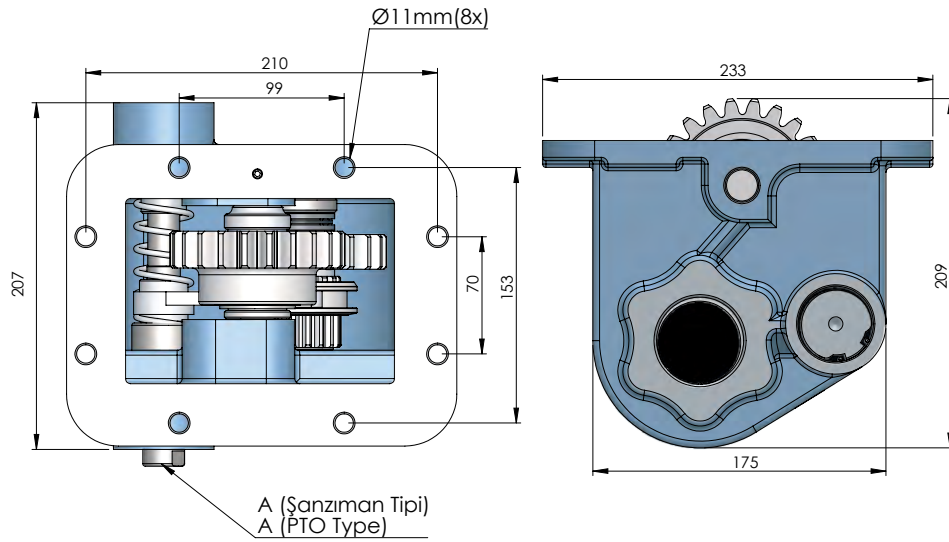
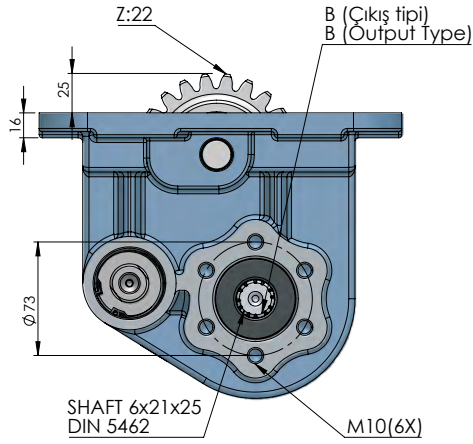

FULLER

POWER TAKE-OFFS
P.T.O.

CODE KOD	TYPE TİP (A)	MOUNTING TYPE BAĞLANTI TİPİ (B)	MOUNTING SIDE BAĞLANTI	TORQUE TORK (Kgm / Nm)	POWER GÜÇ (Hp / Kw)	SPEED DEVİR (RPM)	RATIO ORAN
50520212P0	PNEUMATIC PNÖMATİK	UNI	BOTTOM ALT TAN	40 Kgm 392.4 Nm	57.8 Hp 43.1 Kw	1050 RPM	1:1
50520222P0		ISO ADAPTER ADAPTÖRLÜ ISO					
50520232P0		FLANGE FLANŞLI					
50520242P0		SHAFT ŞAFTLI					
GEARBOX / ANA ŞANZIMANLAR				USED VEHICLES / KULLANILAN BAZI ARAÇLAR			
RTO 11609-11613-11709-12709-14609 MRT0 / RTX 9509-9513-9710-11509-14613-15613-15615 A/B/H RT16108LL/FTS16108LL 16908LL(1050 RPM, SAĞ)				19.361-26.321-26.240-26.280 MAN/180.24-280.26-190.26-190.30-190.35-190.42-198.38-240.36 -330.26-330.30-330.35-380E30 IVECO/270-26 FATİH BMC/DAF 85-2605-2800-2815-3030-3300 -3330-3600-4400 -ERF E6-E8-E12-EC 14 LEYLAND/FODEN 4000/MAGIRUS/ 19.320-30.280 MAN / FIAT 619-697			

Seçeğinizin pompanın dönüş yönü, P.T.O. dönüş yönü ile ters olmalıdır.
The rotation of the choosen pump has to be opposite with the rotation of P.T.O.

P.T.O. montaj edildikten sonra ana şanzıman yağını tamamlayın.
Fill the oil of the gear box after mounting the P.T.O.

management of power