

MERCEDES G4-1 TEK DİŞLİ ISO

MERCEDES G4-1 SINGLE GEAR ISO

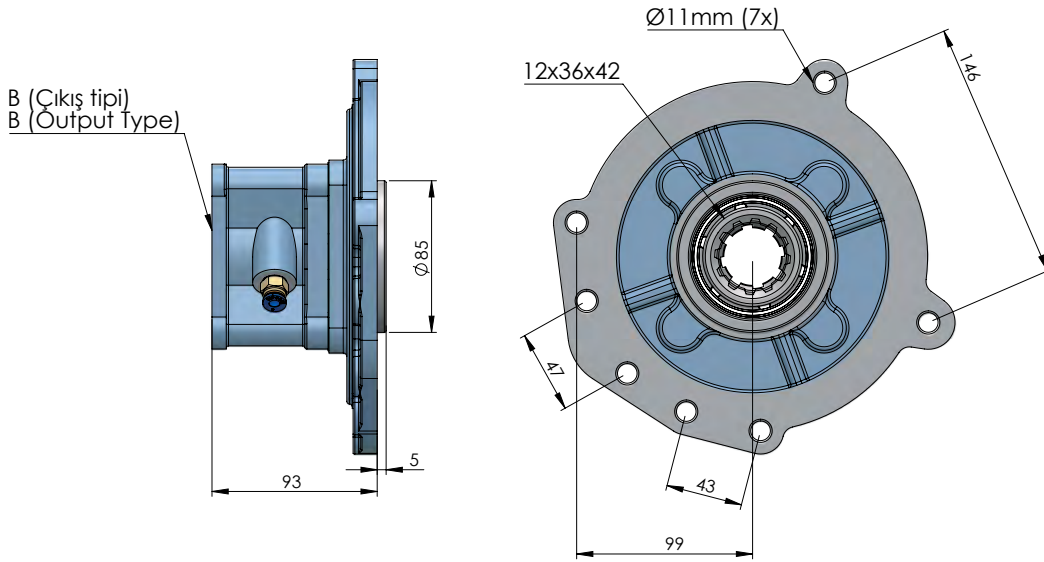
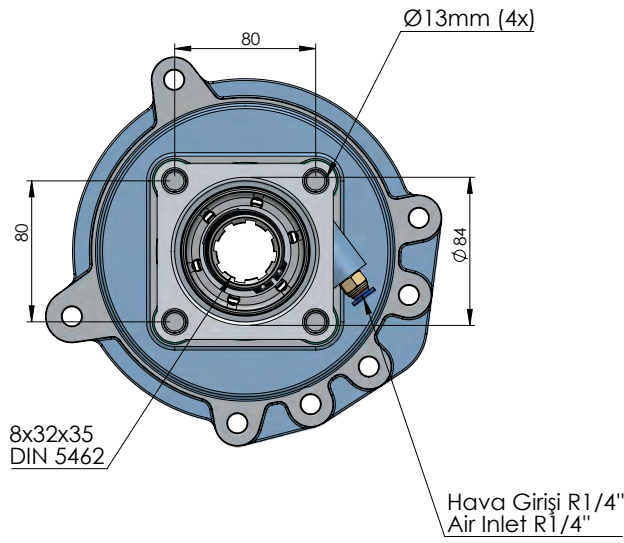

CODE KOD	TYPE TİP (A)	MOUNTING TYPE BAĞLANTI TİPİ (B)	MOUNTING SIDE BAĞLANTI	TORQUE TORK (Kgm / Nm)	POWER GÜÇ (Hp / Kw)	SPEED DEVİR (RPM)	RATIO ORAN
50129312P0	PNEUMATIC PNÖMATİK	UNI ADAPTER ADAPTÖRLÜ UNI	REAR KUYRUK	23,5 Kgm 230,5 Nm	16 Hp 12 Kw	500	1:1
50129322P0		ISO					
50129332P0		FLANGE ADAPTÖRLÜ FLANŞLI					
50129342P0		SHAFT ADAPTÖRLÜ ŞAFTLI					
GEARBOX / ANA ŞANZİMANLAR				USED VEHICLES / KULLANILAN BAZI ARAÇLAR			
G4 - GV / 4 65,90,95,110				1222-1224-1417-1419-1617-1619-1620-1722-1733-1817-1820-1821-1827-1831-1922-2232-2517 -2521-2527-3027-1424-1628-1820-1824-1929-1935-1948-2024-2222-2426-2524-2622-2629-2635 MERCEDES-BENZ			