

EATON 4106 DOUBLE GEAR UNI

EATON 4106 GRUBA SABİT AKTARMA UNİ

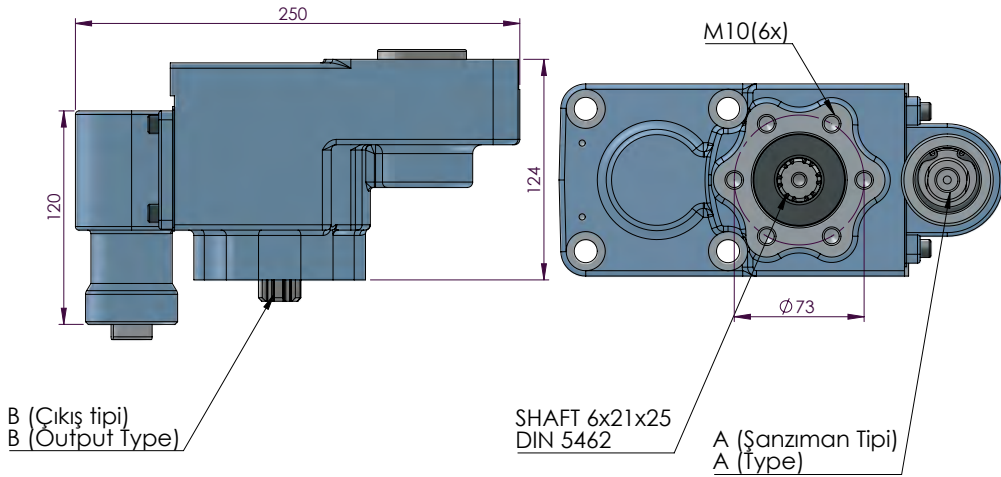
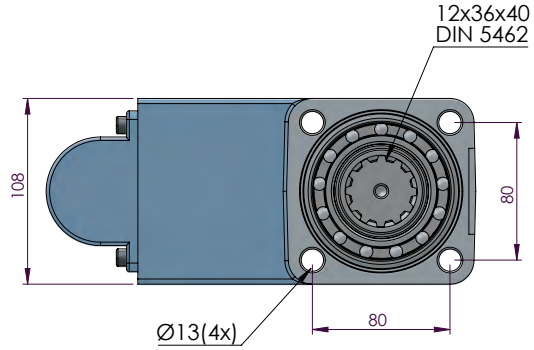

CODE KOD	TYPE TİP (A)	MOUNTING TYPE BAĞLANTI TİPİ (B)	MOUNTING SIDE BAĞLANTI	TORQUE TORK (Kgm / Nm)	POWER GÜÇ (Hp / Kw)	SPEED DEVİR (RPM)	RATIO ORAN
50413311P0	PNEUMATIC PNÖMATİK	UNI	REAR KUYRUK	22,4 Kgm 219,7 Nm	18,5 HP 13,8 Kw	600 RPM	1/1,12
50413321P0		ISO ADAPTER ADAPTÖRLÜ ISO					
50413331P0		FLANGE FLANŞLI					
50413341P0		SHAFT ŞAFTLI					
GEARBOX / ANA ŞANZIMANLAR				USED VEHICLES / KULLANILAN BAZI ARAÇLAR			
PTO EATON FS/FSO/H/V 4106-5206 A/B/H				80-617-620-622 BMC PRO / 200.26-180 FATİH BMC2520 FORD CARGO / AS 950 / CHRYSLER 180.12-210-220 CD-320 MIDLUM RENAULT / FODEN 2000 /ERF E6.18 / 1415-1718 FORD 8.163- 8.224-18-224 MAN/ FEDON ATKINSON E6.11 /			