

## SCANIA GRS905

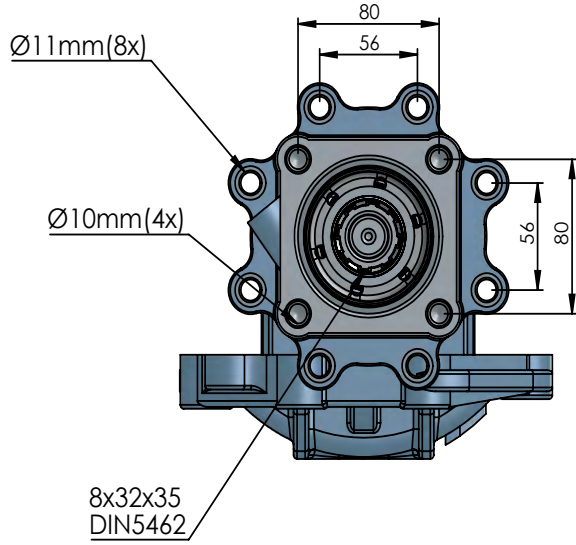
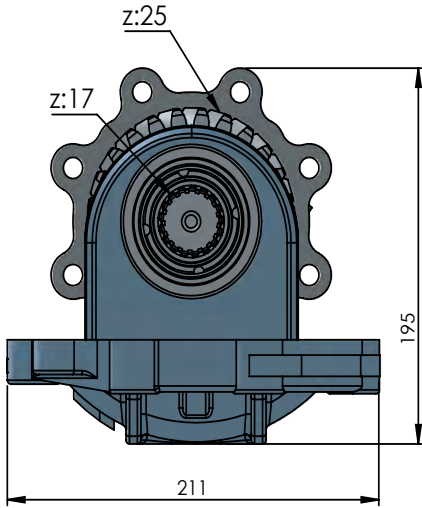
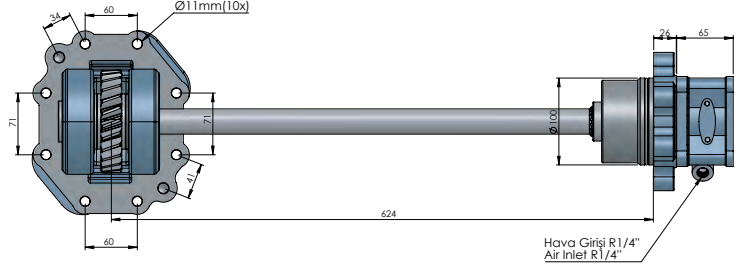

CODE KOD	TYPE TİP (A)	MOUNTING TYPE BAĞLANTI TİPİ (B)	MOUNTING SIDE BAĞLANTI	TORQUE TORK (Kgm / Nm)	POWER GÜÇ (Hp / Kw)	SPEED DEVİR (RPM)	RATIO ORAN
50312411P0	PNEUMATIC PNÖMATİK	UNI ADAPTER ADAPTÖRLÜ UNI	REAR KUYRUK	44.8 Kgm 436 Nm	56.8 Hp 42.4 Kw	1250 RPM	1:1
50312421P0		ISO					
50312431P0		FLANGE ADAPTÖRLÜ FLANŞLI					
50312441P0		SHAFT ADAPTÖRLÜ ŞAFTLI					
GEARBOX / ANA ŞANZİMANLAR				USED VEHICLES / KULLANILAN BAZI ARAÇLAR			
GR 875 / GR 905 / GRS 905 / GRSO 906 / GRS 906 (1250 RPM, SOL)				R420-G 420-G 400 EURO 5- R 500 SCANIA / 18.460 MAN TGS			