

## SCANIA GRS900 ISO

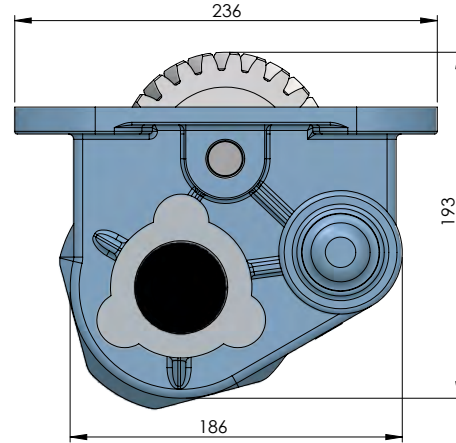
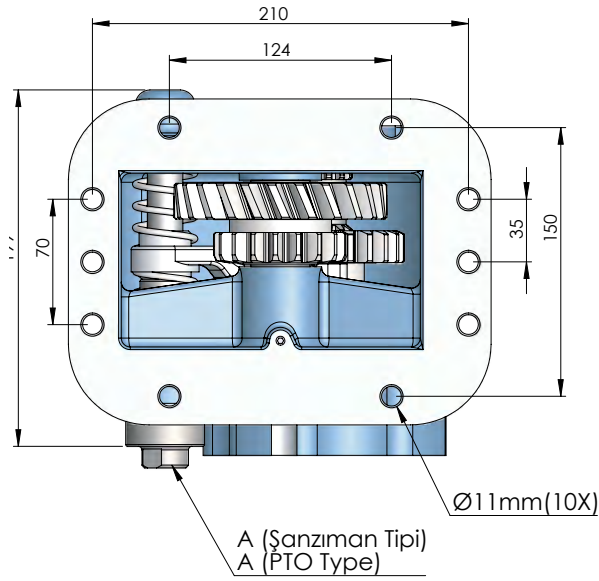
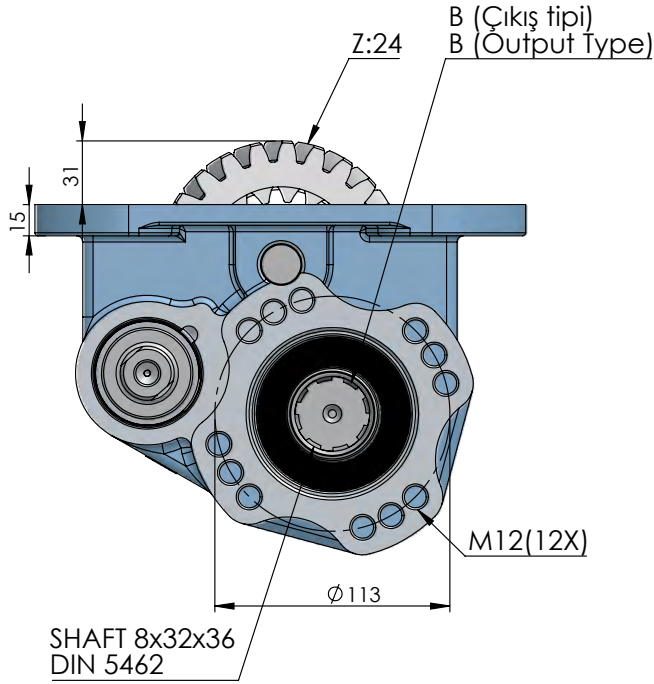

CODE KOD	TYPE TİP (A)	MOUNTING TYPE BAĞLANTI TİPİ (B)	MOUNTING SIDE BAĞLANTI	TORQUE TORK (Kgm / Nm)	POWER GÜÇ (Hp / Kw)	SPEED DEVİR (RPM)	RATIO ORAN
50331512P0	PNEUMATIC PNÖMATİK	UNI ADAPTER ADAPTÖRLÜ UNI	SIDE YAN	25 Kgm 245 Nm	45.3 Hp 33.8 Kw	1065 RPM	01:00,8
50331522P0		ISO					
50331532P0		FLANGE ADAPTÖRLÜ FLANŞLI					
50331542P0		SHAFT ADAPTÖRLÜ ŞAFTLI					
GEARBOX / ANA ŞANZIMANLAR				USED VEHICLES / KULLANILAN BAZI ARAÇLAR			
GRS 900/GRS 890/GRS 920 (1065 RPM, SAĞ)				124 G 420-113-124 L 400-144 L 530-124 LA 420-144 LA 460 144 LA 530-R124 LA 420/R 124 GA 420-143H-143M-143.400-143.450-143.500-R580-R124GA/CB-R164 GA SCANIA			