

EATON 475 AKTARMA LI UNI

EATON 475 DOUBLE GEAR UNI

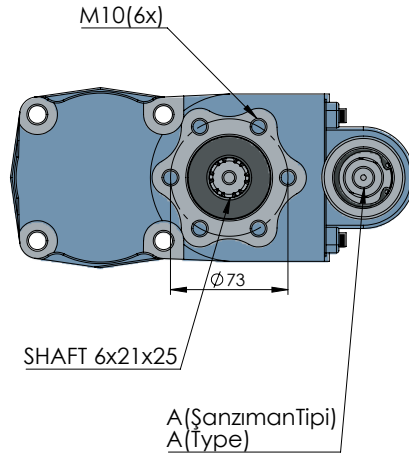
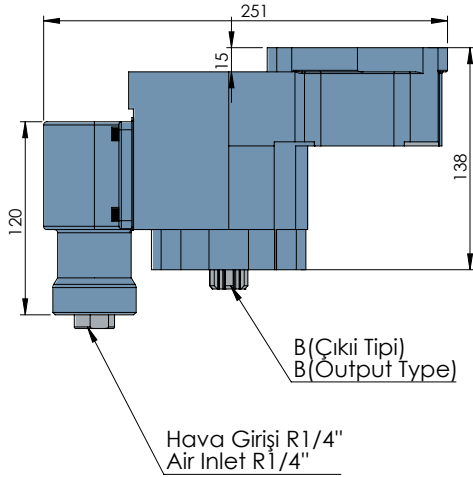
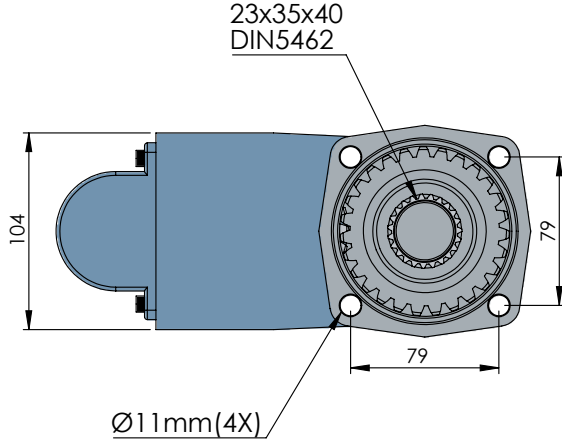

CODE KOD	TYPE TİP (A)	MOUNTING TYPE BAĞLANTI TİPİ (B)	MOUNTING SIDE BAĞLANTI	TORQUE TORK (Kgm / Nm)	POWER GÜÇ (Hp / Kw)	SPEED DEVİR (RPM)	RATIO ORAN
50410311P0	PNEUMATIC PNÖMATİK	UNI	REAR KUYRUK	21,5 Kgm 210,9 Nm	19,2 HP 14 Kw	650 RPM	1/1,12
50410321P0		ISO ADAPTER ADAPTÖRLÜ ISO					
50410331P0		FLANGE FLANŞLI					
50410341P0		SHAFT ŞAFTLI					
GEARBOX / ANA ŞANZIMANLAR				USED VEHICLES / KULLANILAN BAZI ARAÇLAR			
PTO EATON-HEMA 475 R SML-SMA-SM0-SME-CMA-CMO				105.08-110.08-145.22 FATİH / 2014-2114-FORD CARGO 1800 INTER / 1212-1312 FORD (83-86) 1812-1814-2014-2117-2517 FORD (86) 140-1340 BMC / ZIL (RUS)			