

ISUZU MOY CR

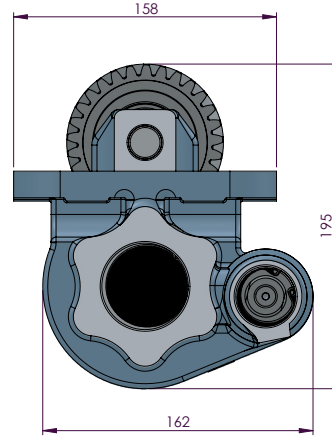
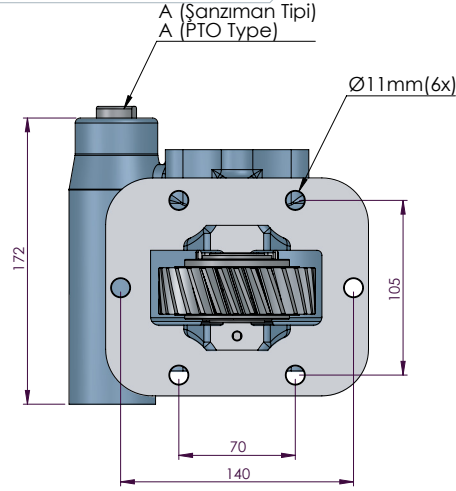
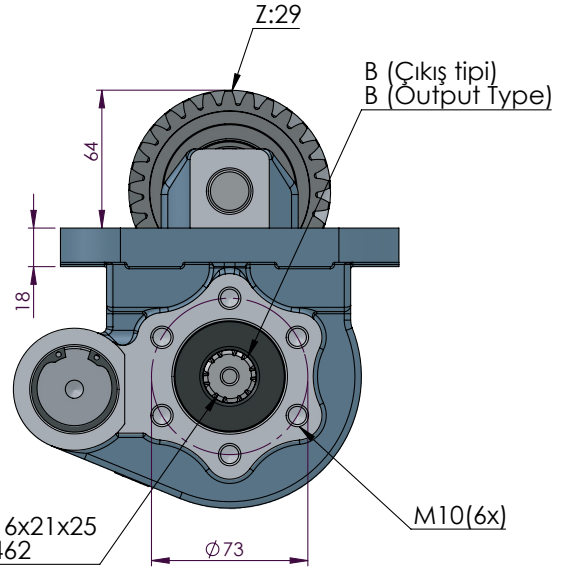

CODE KOD	TYPE TİP (A)	MOUNTING TYPE BAĞLANTI TİPİ (B)	MOUNTING SIDE BAĞLANTI	TORQUE TORK (Kgm / Nm)	POWER GÜÇ (Hp / Kw)	SPEED DEVİR (RPM)	RATIO ORAN
50617512M0	MECHANIC MEKANİK	UNI					
50617522M0		ISO ADAPTER / ADAPTÖRLÜ ISO					
50617532M0		FLANGE / FLANŞLI					
50617542M0		SHAFT / ŞAFTLI					
50617512V0	VACUUM VAKUMLU	UNI	SIDE YAN	23 Kgm 225 Nm	29,4 Hp 22 Kw	1000 RPM	1:1,03
50617522V0		ISO ADAPTER / ADAPTÖRLÜ ISO					
50617532V0		FLANGE / FLANŞLI					
50617542V0		SHAFT / ŞAFTLI					
50617512P0	PNEUMATIC PNÖMATİK	UNI					
50617522P0		ISO ADAPTER / ADAPTÖRLÜ ISO					
50617532P0		FLANGE / FLANŞLI					
50617542P0		SHAFT / ŞAFTLI					
GEARBOX / ANA ŞANZIMANLAR				USED VEHICLES / KULLANILAN BAZI ARAÇLAR			
MYY5T / MOY-9F / MOY-9H / MOYCR / MYY-6S / MOYMB / MOYNA / MYY-5S / MYY-6P / MOYGX / MOY4N / MOYNB / MOYNC / MYY5R / MYY5D / MOYPN / MOYUK / MOYMC / MOYMR / MOYPZ (5,315-5,979)				NLR85L (ED6AYG-HD6AYG) / NNR85L (FD5AYG-HD5AYG) / NPR75L (HL5VAYGN-KL5VAYGNKL5VAYG) NPR 66-71-75-77 ISUZU / NKR 250 / NPR 250 / NKR 66 E2L / HINO 300 SERİ 4X2 / NQR 70 P / ELF NKR71HDEL 130 / NPR 66L-PL / NQR71PL / NPR85L / 4.3 NPR 70 / NKR66E / NPR66P / NQR71R / NPR 66 LL / HINO DUTRO NQR71PL / NPR 75 LONG / NLR LONG / NNR / NNR LONG / NPR 75 / N 10 / NPR 8 / NPR 8 LONG			